

- |           |                          |                   |
|-----------|--------------------------|-------------------|
| <b>1</b>  | 2LSE840032               | Ast-Eiche         |
| <b>2</b>  | 2RSE840032               | Ast-Eiche         |
| <b>3</b>  | 2HQU841529               | Silber            |
| <b>4</b>  | 2XFSM84003<br>2XFSM84007 | Weiß<br>Anthrazit |
| <b>5</b>  | 2ORS842029               | Silber            |
| <b>6</b>  | 2URS842029               | Silber            |
| <b>7</b>  | 2SZL841429               | Silber            |
| <b>8</b>  | 2SZR841429               | Silber            |
| <b>9</b>  | 2OSR842029               | Silber            |
| <b>10</b> | 2USR842029               | Silber            |
| <b>11</b> | 2WBE710000               | Silber            |
| <b>12</b> | 4BB8090002               | Alu               |



<https://quefairedemesdechets.fr>



Raccolta differenziata  
Verifica le disposizioni del tuo Comune

Fackelmann GmbH + Co. KG  
Sebastian-Fackelmann-Str. 6  
91217 Hersbruck • Deutschland  
FAX: 09151/811-294  
Servicetelefon: 09151/811-206  
servicebm@fackelmann.de  
www.fackelmann.de

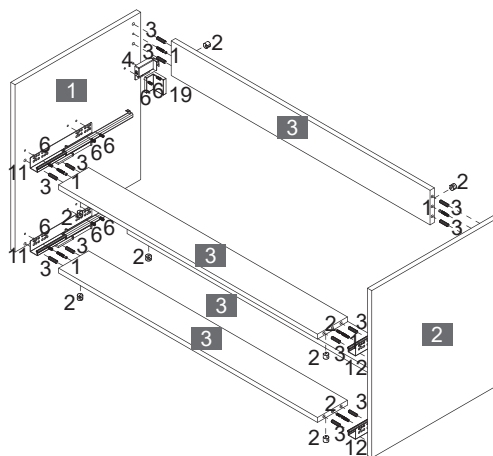
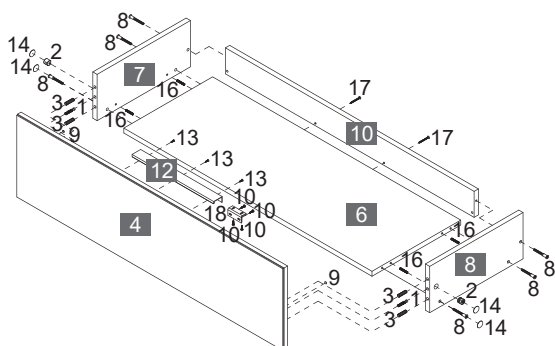
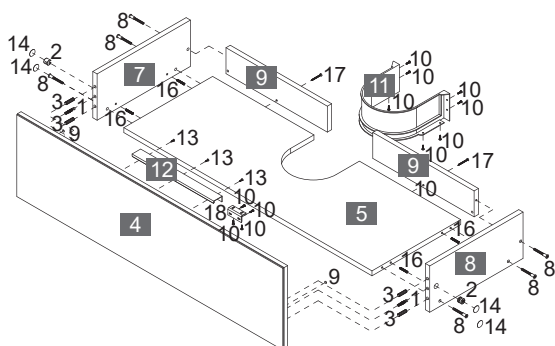
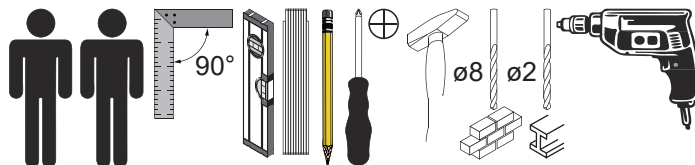
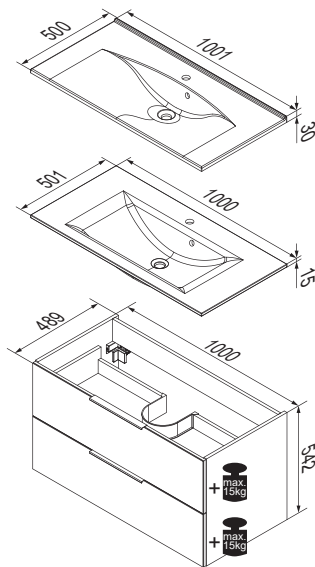

- 1** 2LSE840032 Ast-Eiche
- 2** 2RSE840032 Ast-Eiche
- 3** 2HQU841629 Silber
- 4** 2XFSM84023 Weiß  
2XFSM84027 Anthrazit
- 5** 2ORS842129 Silber
- 6** 2URS842129 Silber
- 7** 2SZL841429 Silber
- 8** 2SZR841429 Silber
- 9** 2OSR842129 Silber
- 10** 2USR842129 Silber
- 11** 2WBE710000 Silber
- 12** 4BB8090002 Alu



<https://quefairedemesdechets.fr>



Raccolta differenziata  
Verifica le disposizioni del tuo Comune

Fackelmann GmbH + Co. KG  
Sebastian-Fackelmann-Str. 6  
91217 Hersbruck • Deutschland  
FAX: 09151/811-294  
Servicetelefon: 09151/811-206  
servicebm@fackelmann.de  
www.fackelmann.de

1	2	3	4	5	6	7	8	9
4BB1500001	4BB1515000	Ø8x30mm 4BD008X300	4BB84L1826	4BB84RE826	Ø6.3x13mm 4SK6.3X130	4XBB81HDN2	Ø6.3x50mm 4SK6.3X500	2BB268X1.6
12 x	12 x	24 x	1 x	1 x	16 x	1 x	12 x	4 x

10	11	12	13	14	15	16	17	18
Ø3,5x13mm 4RK3.5X131	4BBKA35013	4BBKA35014	Ø3,0x12mm 4SK3.0X120	Ø20mm Silber 4BB0020002	Ø3,5x20mm 4RK3.5X200	Ø5x30mm 4BD05X2800	Ø3,5x40mm 4SK3.5X400	4BW5022160
16 x	2 x	2 x	6 x	8 x	4 x	8 x	4 x	2 x

19

2XBB843002

1 x

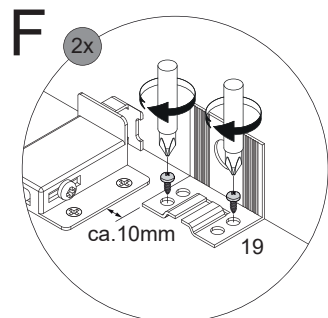
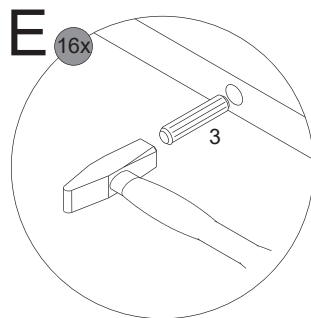
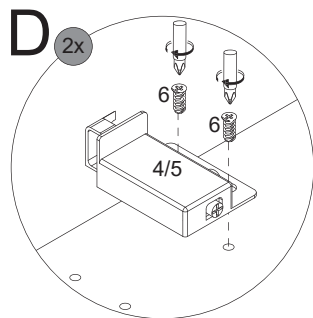
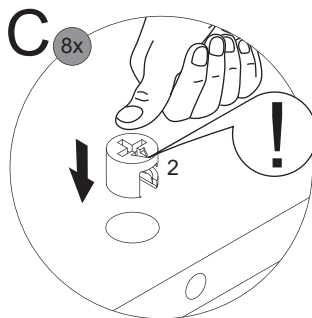
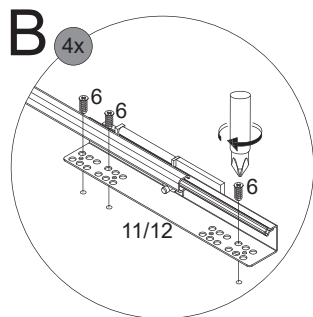
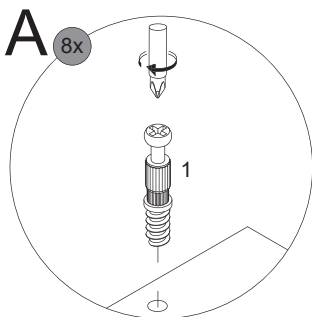
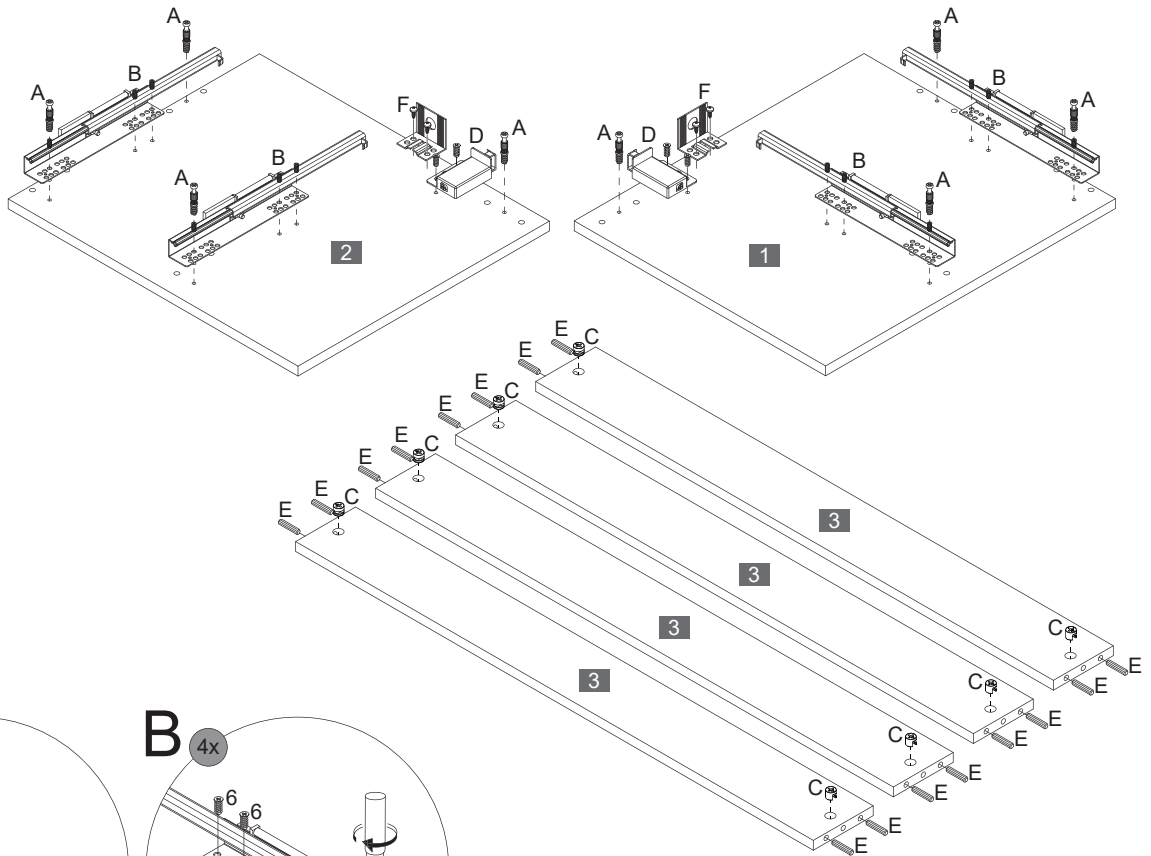

2

2.1

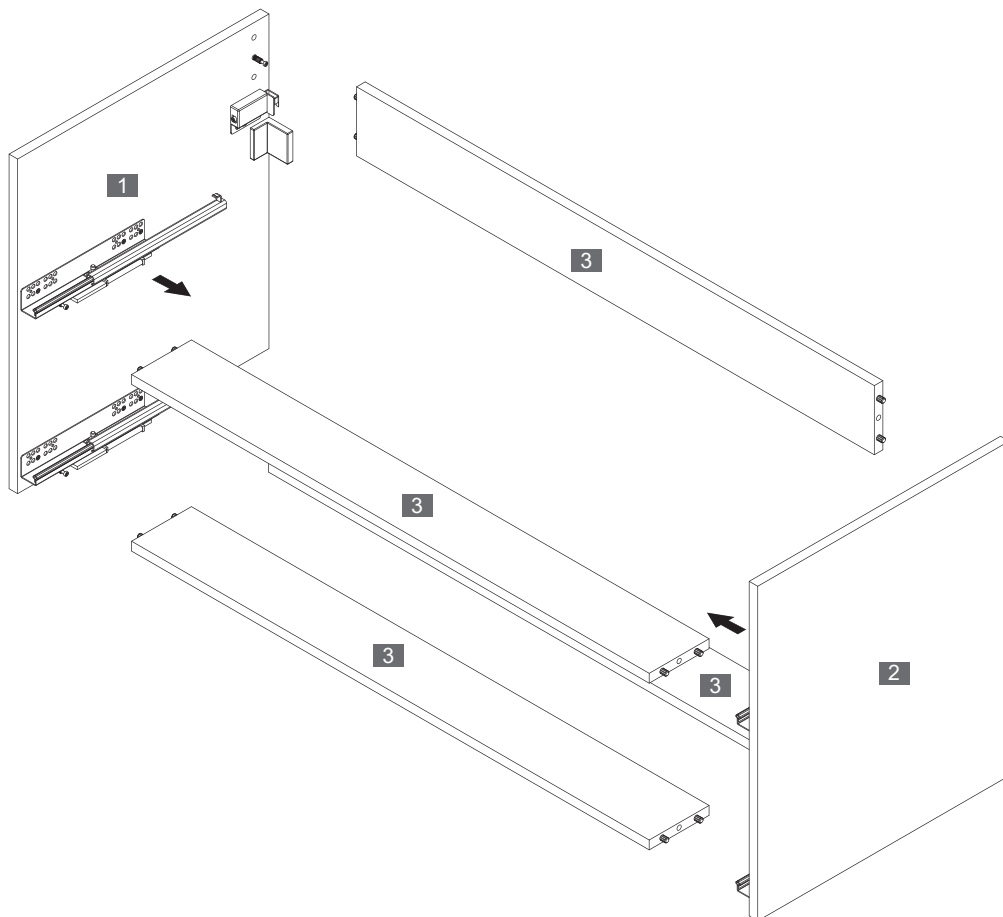

2.2

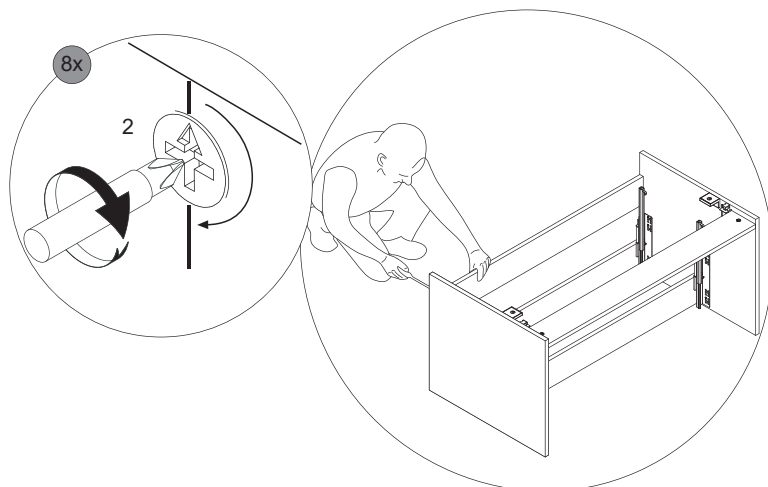

# 3

3.1

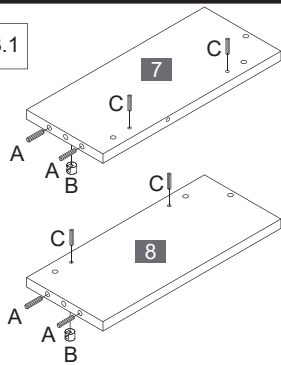

A 4x

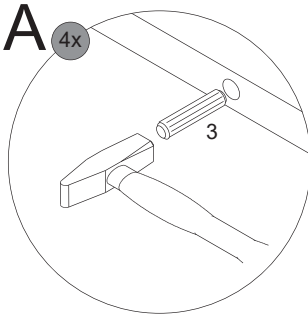

B 2x

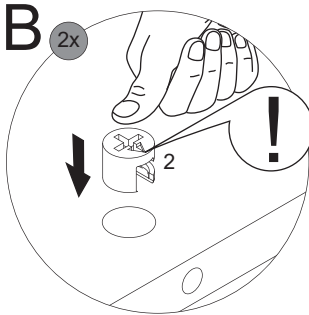

C 4x

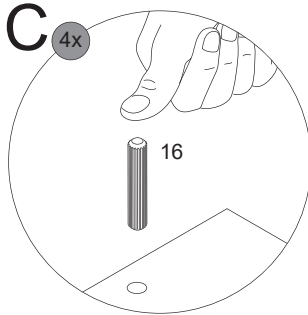

3.2

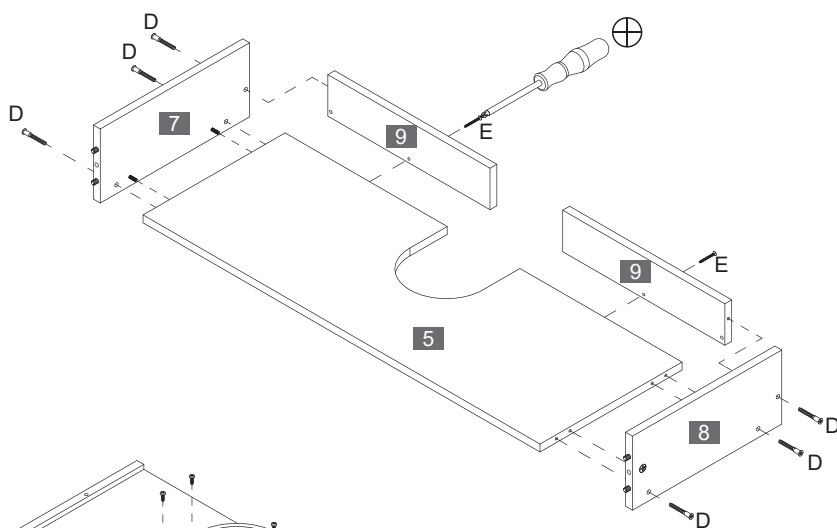

D 6x

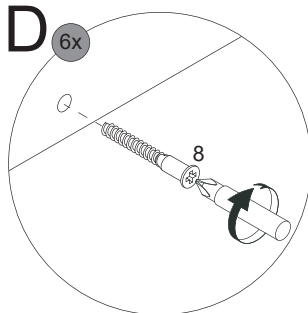

E 2x

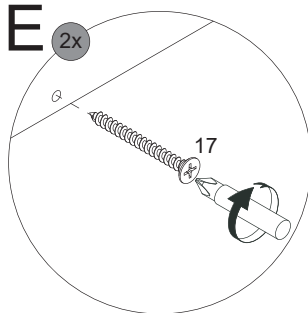

3.3

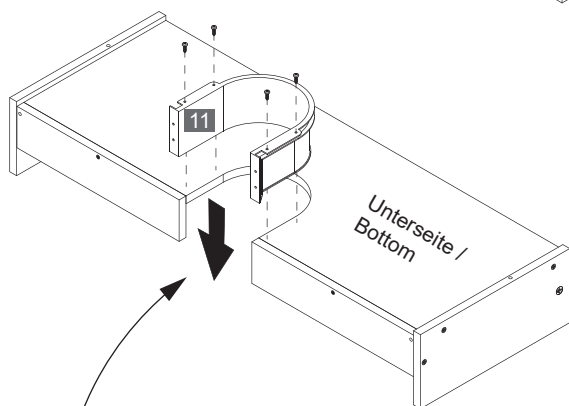

8x

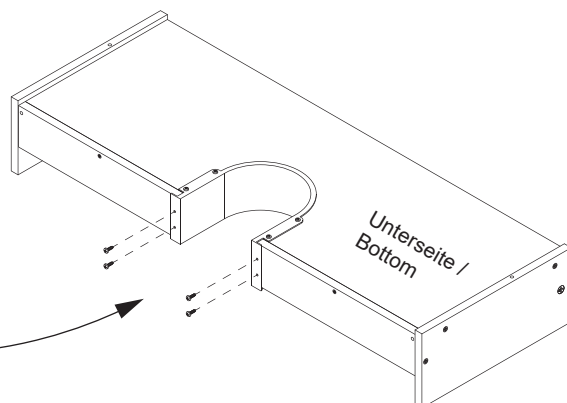
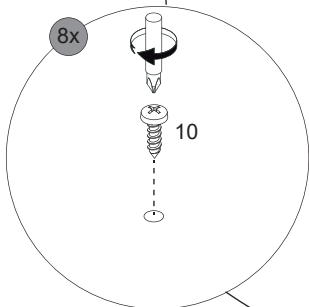

3.4

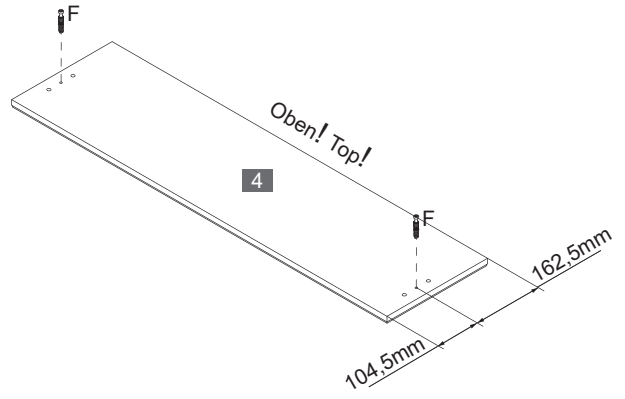
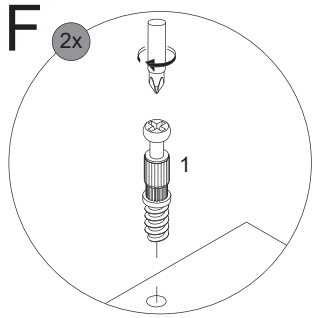

3.5

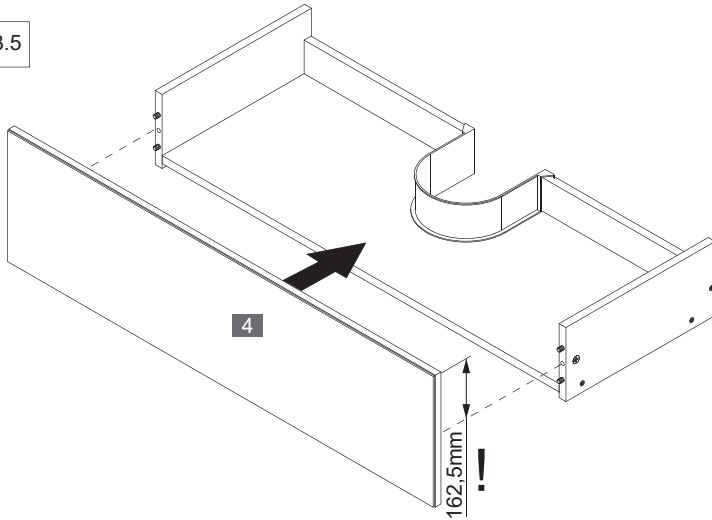

3.6

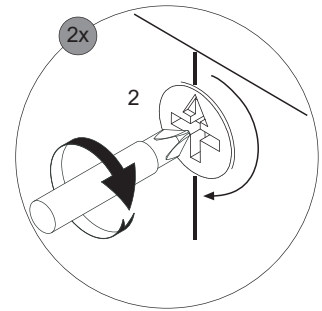

3.7

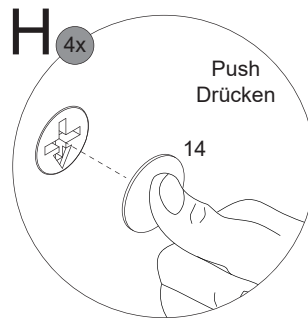
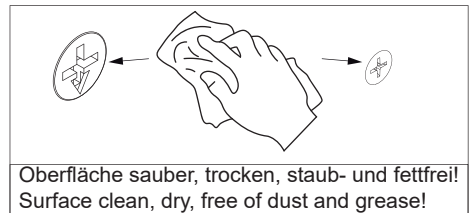
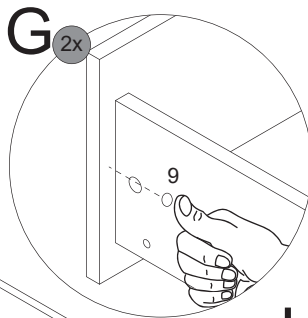
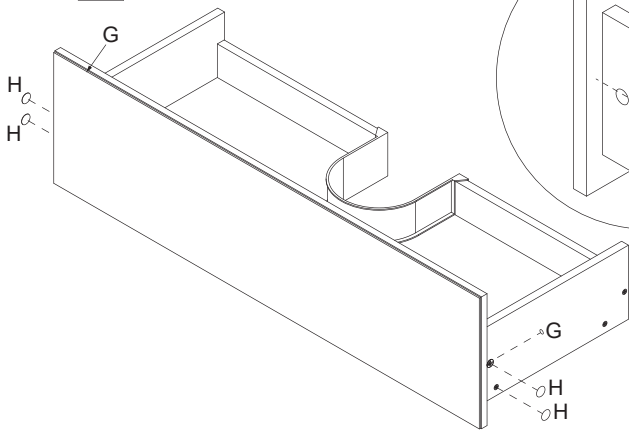

3.8

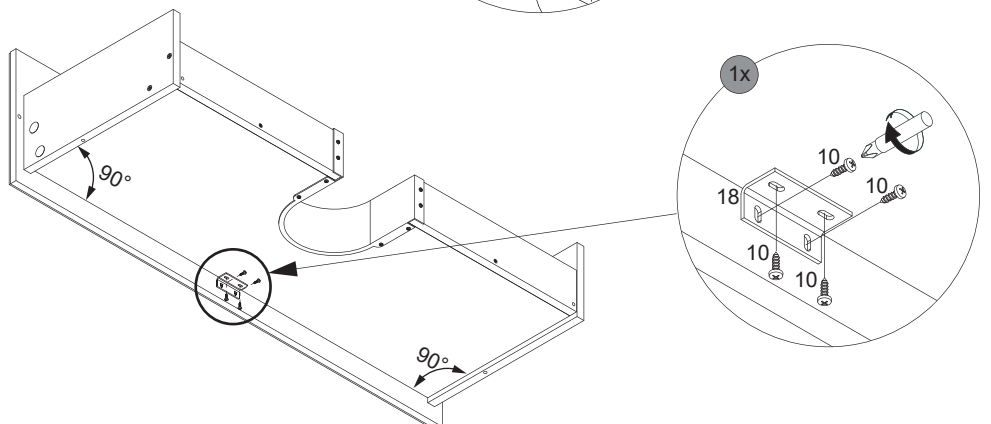

4

4.1

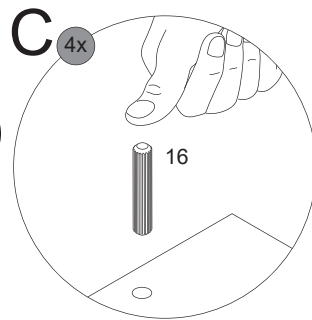
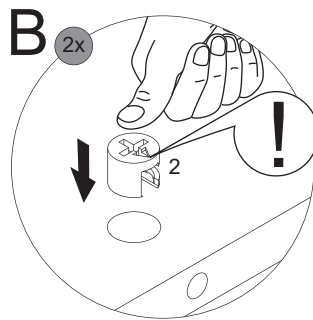
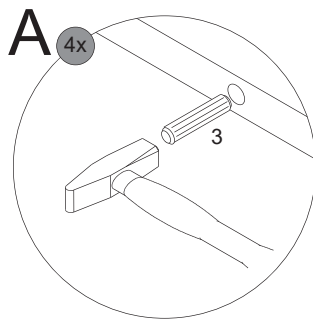
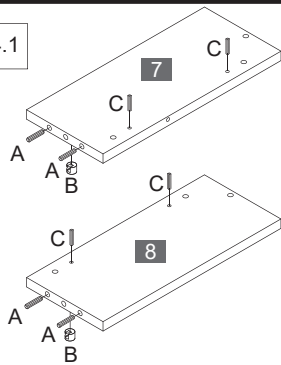

4.2

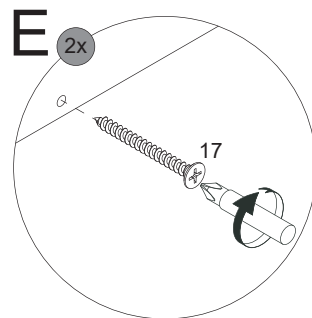
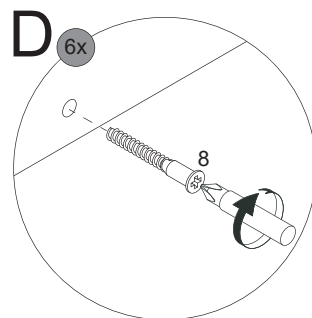
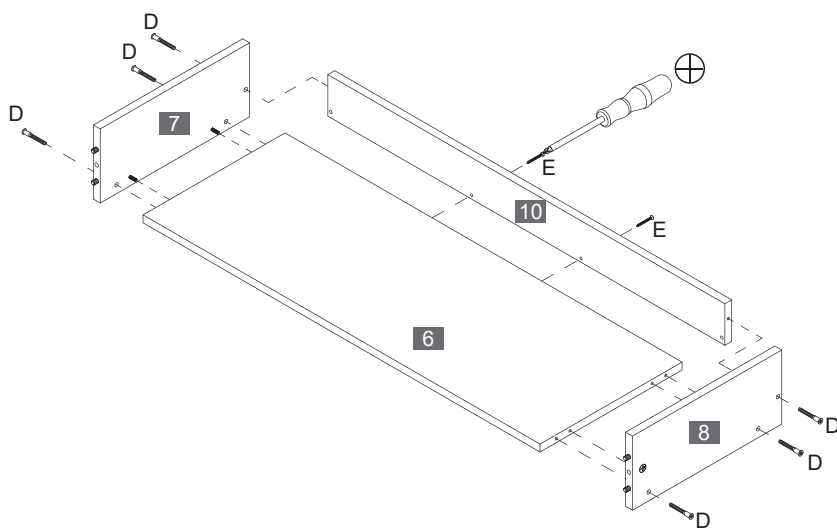

4.3

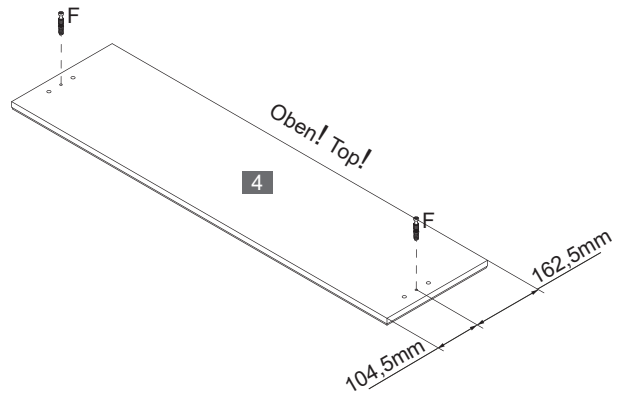
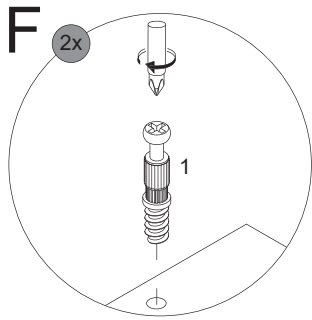

4.4

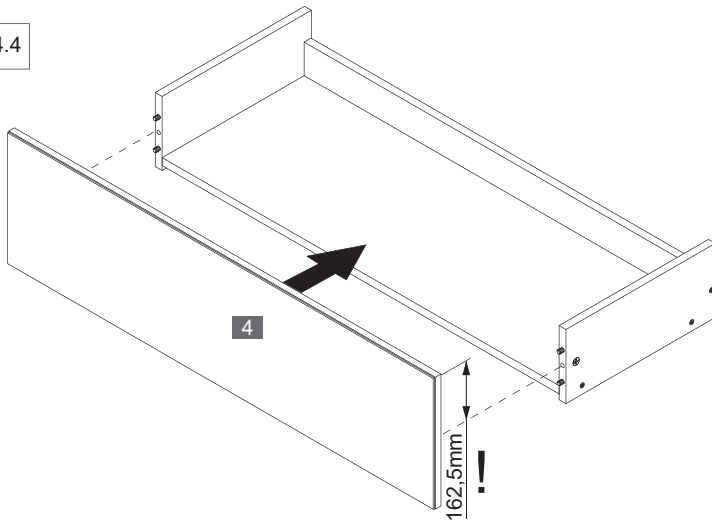

4.5

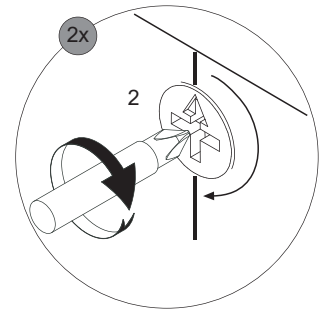

4.6

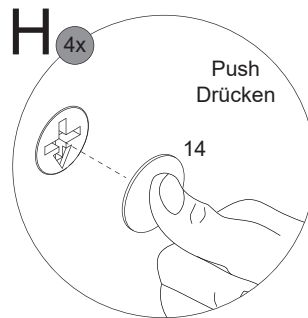
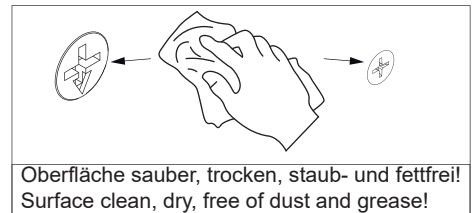
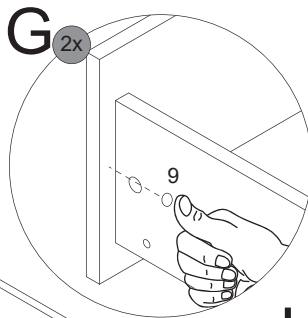
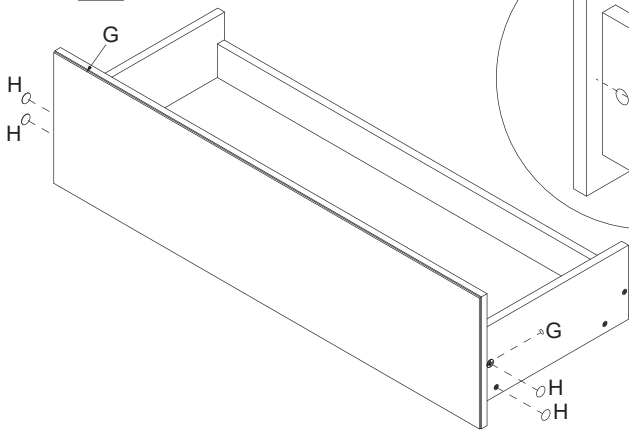

4.7

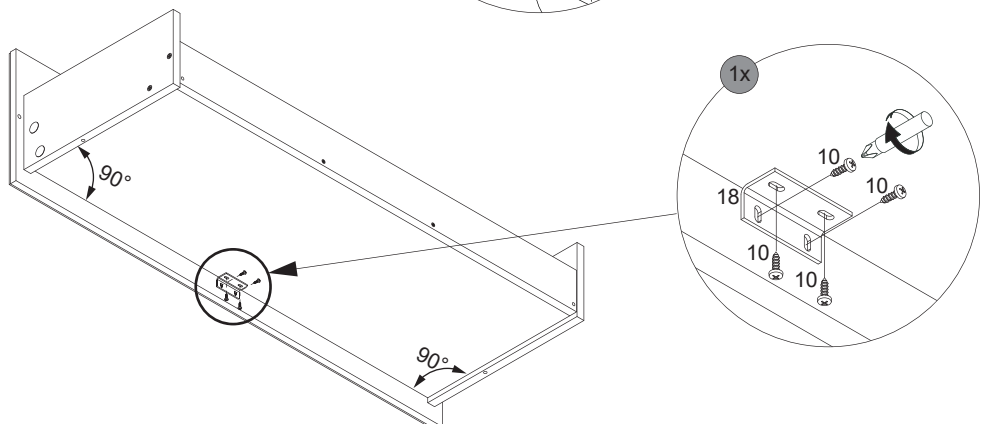

5

A

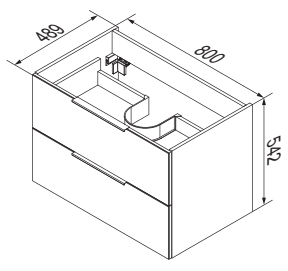

B

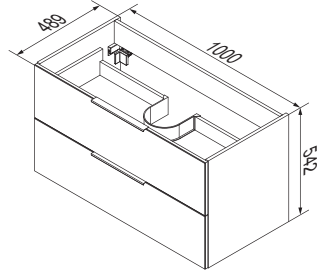

! Alle Maße sind in Millimetern angegeben, unverbindlich, vor Ort zu prüfen und stellen nur eine Empfehlung dar. Änderungen vorbehalten. All dimensions are given in millimeters, without obligation, to be checked on site and represent only a recommendation. Subject to change.

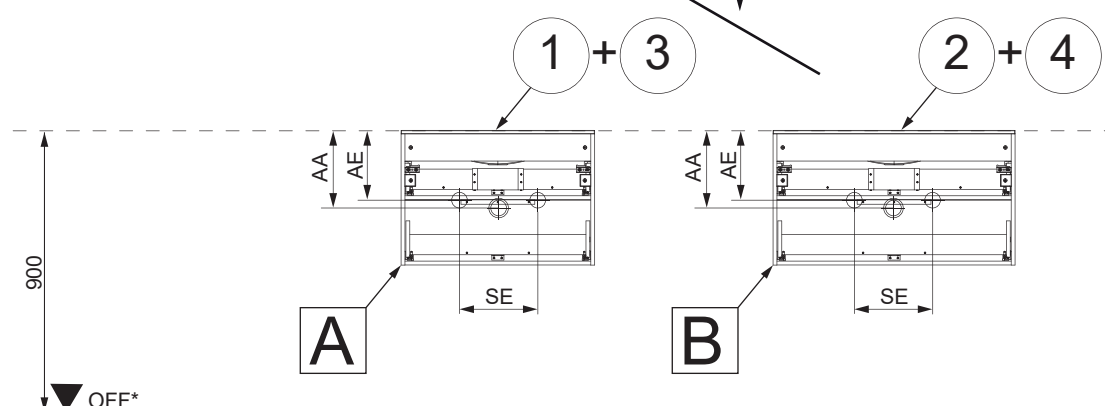
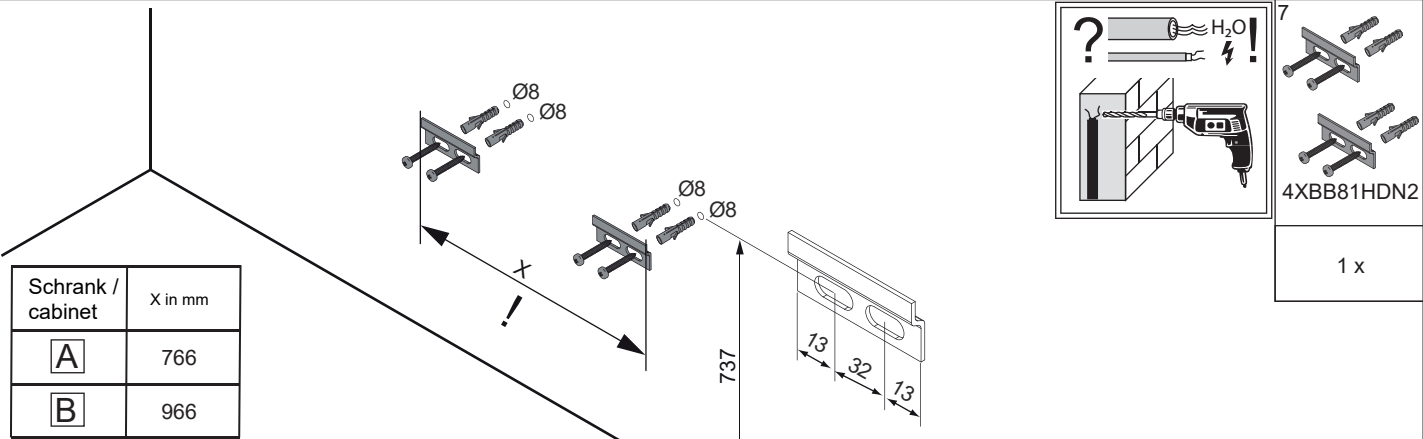

Ansicht von hinten  
View from the back

Washbecken	AA	AE	SE	Siphon	Washbecken	AA	AE	SE	Siphon
<b>1</b> 	260 - 320	170 - 480	150 - 330	Bei Standard-Siphon 	<b>3</b> 	280 - 340	180 - 500	150 - 330	Bei Standard-Siphon 
	270 - 440	170 - 480	150 - 330	Bei Raumspar-Siphon 		290 - 450	180 - 500	150 - 330	Bei Raumspar-Siphon 
<b>2</b> 	260 - 320	170 - 480	150 - 330	Bei Standard-Siphon 	<b>4</b> 	280 - 340	180 - 500	150 - 330	Bei Standard-Siphon 
	270 - 440	170 - 480	150 - 330	Bei Raumspar-Siphon 		290 - 450	180 - 500	150 - 330	Bei Raumspar-Siphon 

AE = Abstand Eckventile  
Distance corner valves

AA = Abstand Ablauf  
Distance drain

SE = Seitlicher Abstand Eckventile  
Lateral distance corner valves

\*OFF = Oberkante fertiger Fußboden  
Top edge of finished floor

**6**

6.1

2x

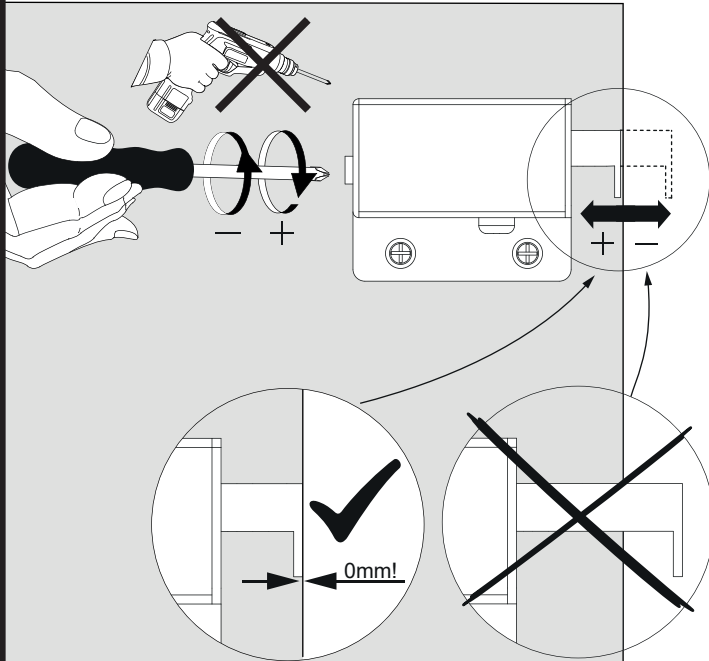

6.2

2x

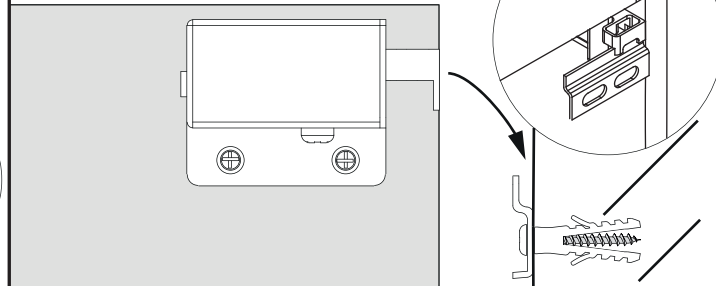

6.3

2x

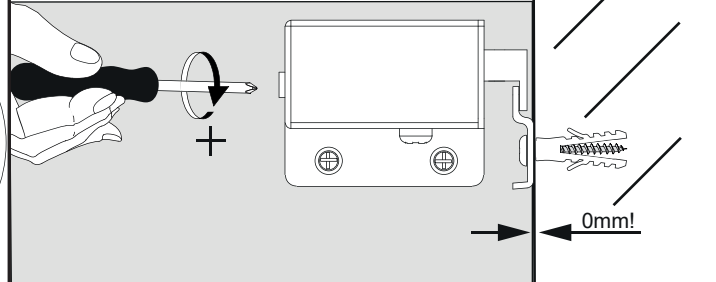
**7**

Zusätzliche Wandbefestigung für Waschtischunterschranke und Beckenunterschranke zur Einhaltung der Norm EN 14749 unbedingt einbauen! Beigefügtes Wandbefestigungs-Material ist nur für Massivwände geeignet. Zur Befestigung an anderen Wänden müssen Spezialdübel verwendet werden.

In compliance to the norm EN 14749 please make sure to built-in the additional wall-fastenings for sink cabinets and vanities. Attached wall-fastening-material is for massive walls only. For mounting on all other walls please use special dowels.

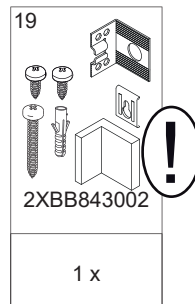

Maße bauseits prüfen!  
Check dimensions on site!

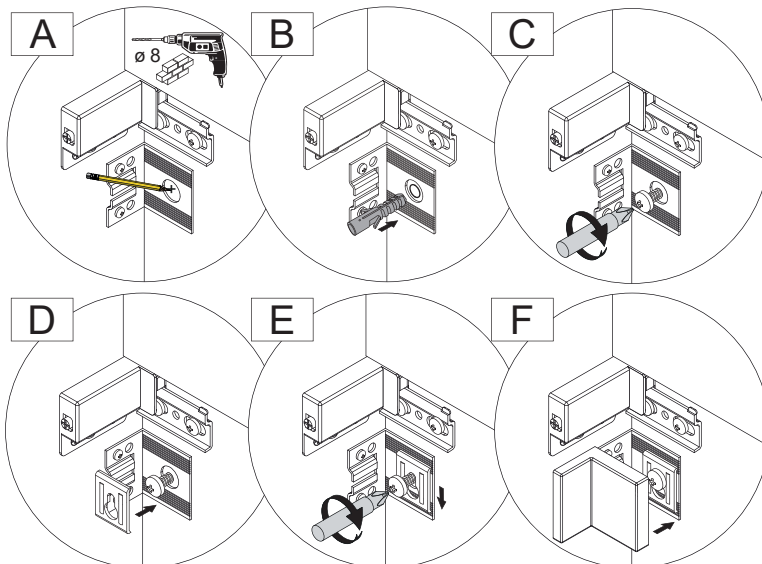
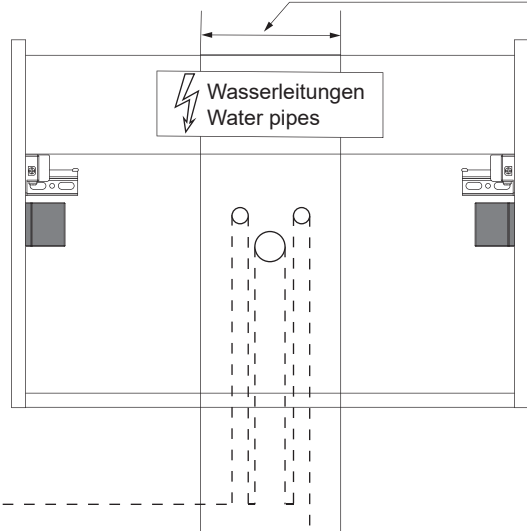

8

8.1

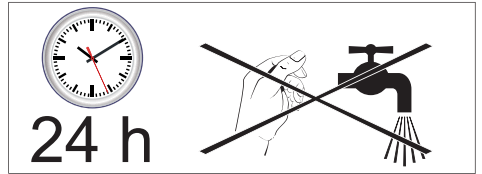
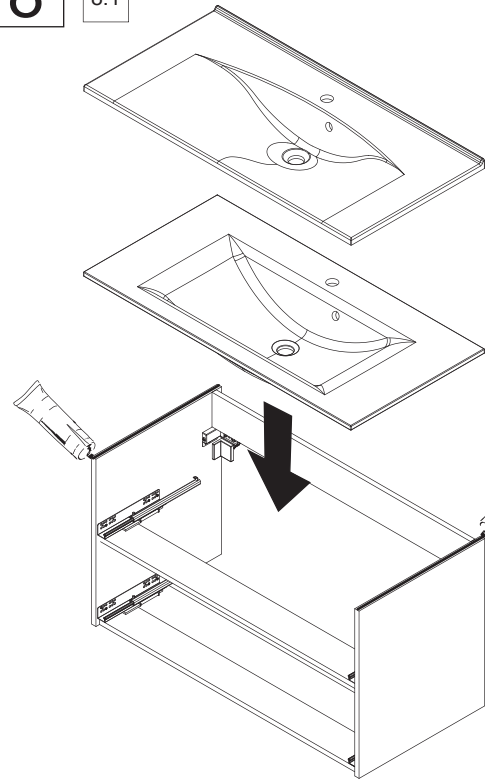

8.2

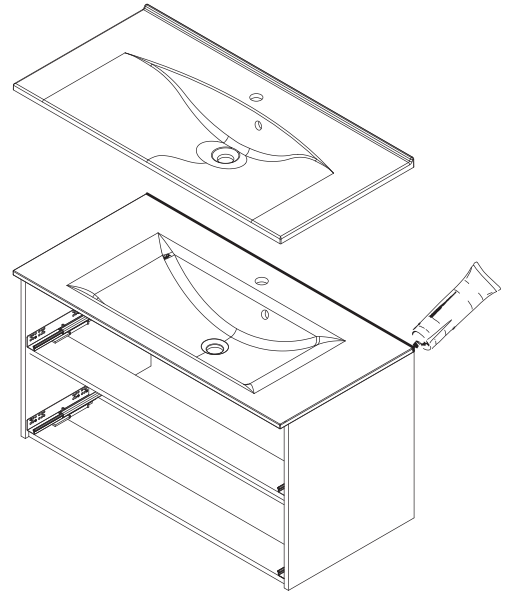

**i** Silikon nicht inklusive  
Silicone is not included

9

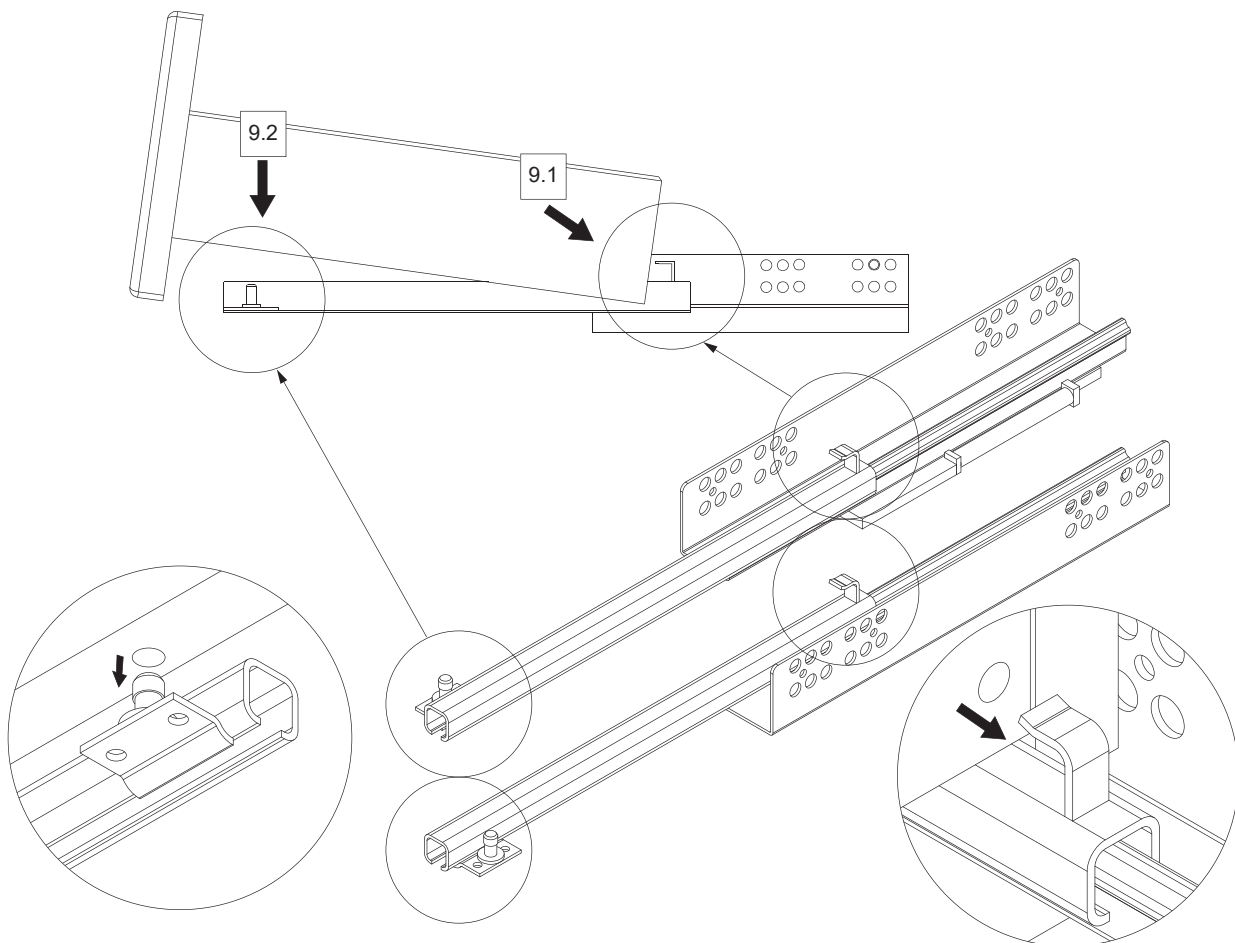

# 10

10.1

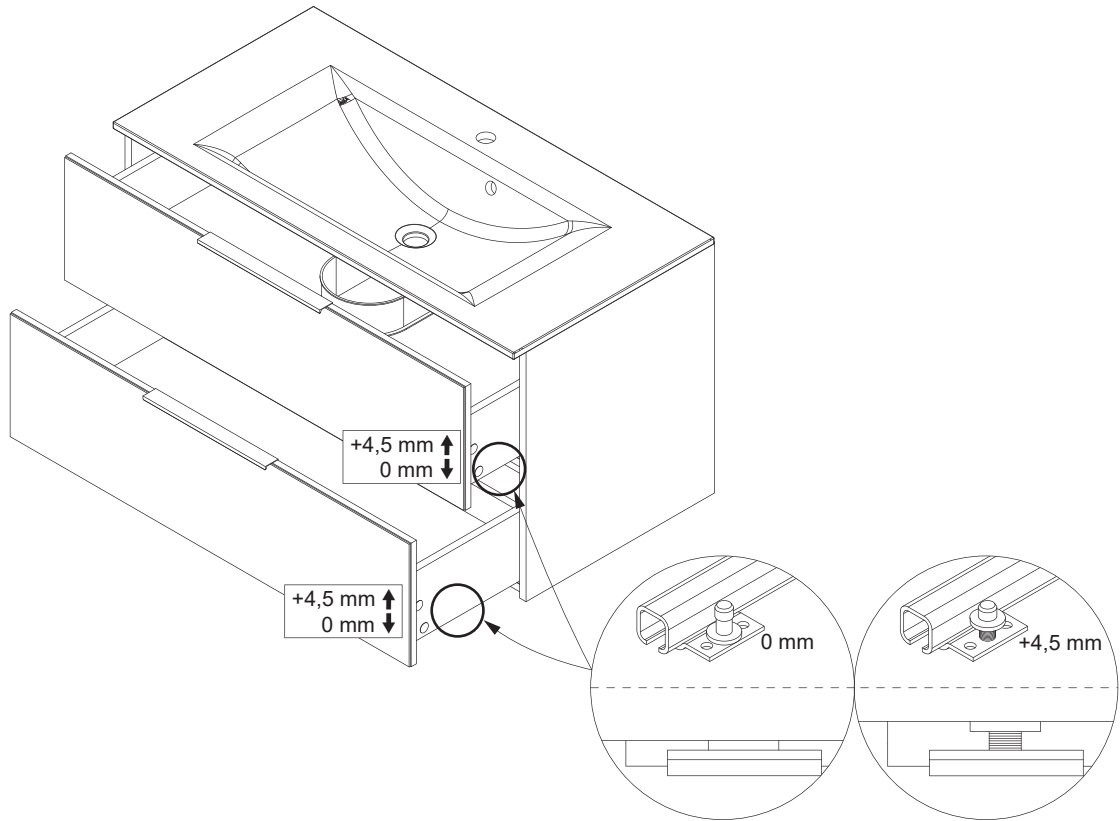

10.2

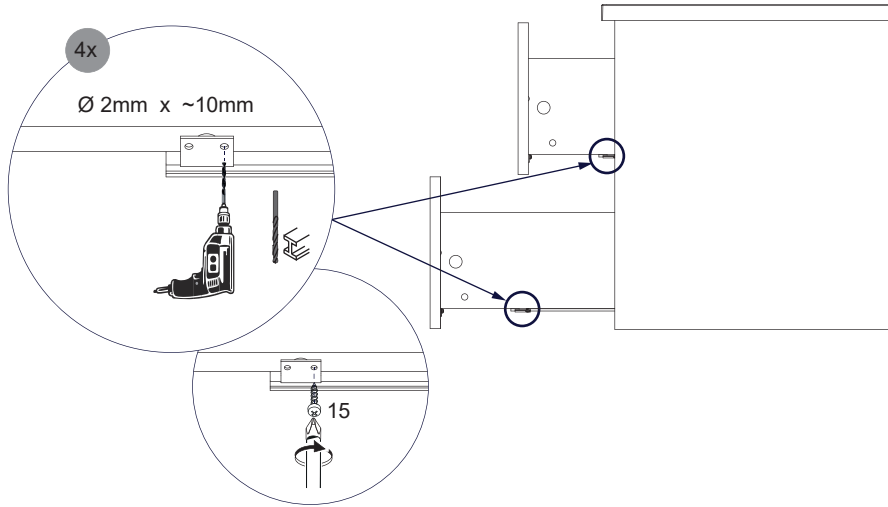

# 11

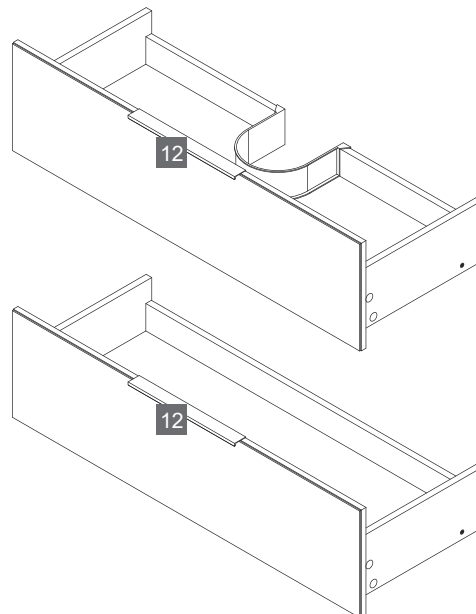
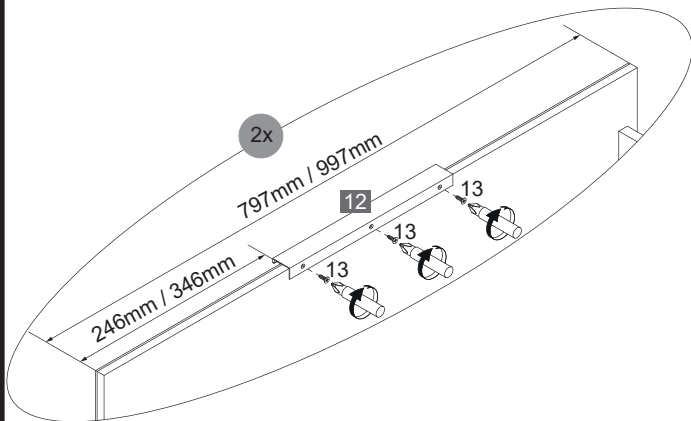

13



Ø3,0x12mm

4SK3.0X120

6 x